

**SONY®**

**FM/MW/LW/SW 4 BAND RECEIVER**

# ICF-32

**OPERATING INSTRUCTIONS** page 6

**MODE D'EMPLOI** page 14

● If you fold this page back, you will see the illustrations which will explain how to operate your radio.

● Déplier cette page. Les illustrations indiquent comment faire fonctionner la radio.

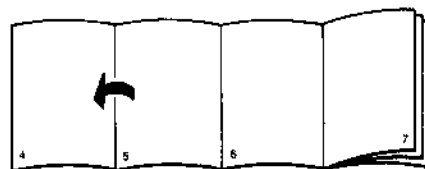
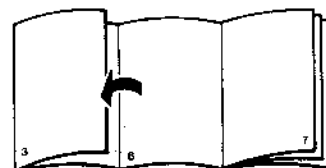

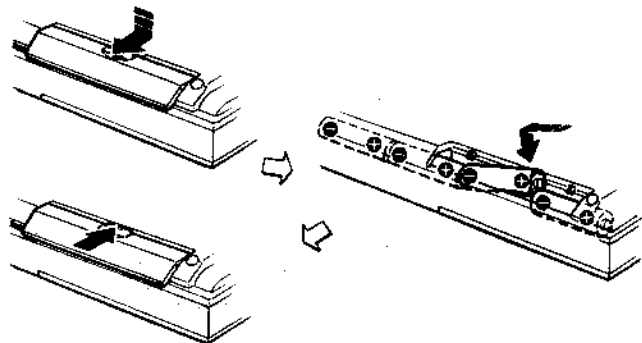
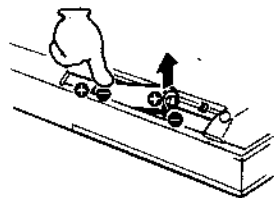
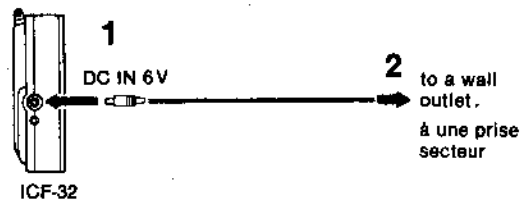
**A****B****C**

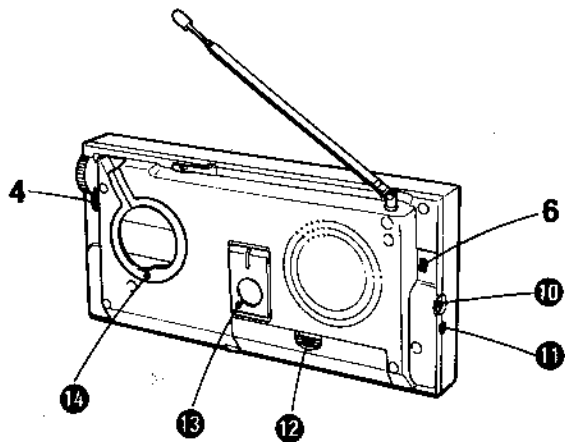
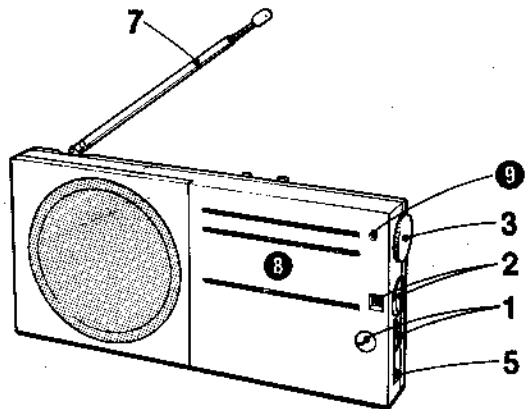
**D**

4

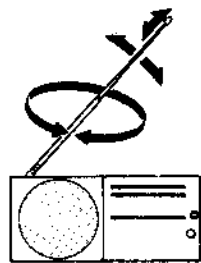
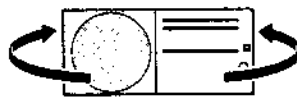
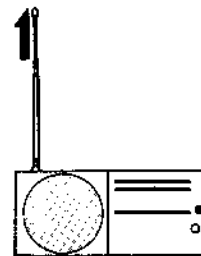
**E 1****2****3**

5

Before operating the set, please read this manual thoroughly. This manual should be retained for future reference.

This instruction manual covers three models: the model available in Canada, the model available in the United Kingdom and the model available in European countries. The differences among the models are clearly described in the text.

## WARNING

To prevent fire or shock hazard, do not expose the set to rain or moisture.

To avoid electrical shock, do not open the cabinet. Refer servicing to qualified personnel only.

## Notice For the Customers in the United Kingdom

### Important

The wires in the mains lead are coloured in accordance with the following code:

Blue: Neutral

Brown: Live

As the colours of the wires in the mains lead of this apparatus may not correspond with the coloured markings identifying the terminals in your plug proceed as follows:

The wire which is coloured blue must be connected to the terminal which is marked with the letter N or coloured black.

The wire which is coloured brown must be connected to the terminal which is marked with the letter L or coloured red.

## TABLE OF CONTENTS

Features .....	7
Precautions .....	8
Power sources .....	8
How to use .....	10
Specifications .....	12
Troubleshooting guide .....	13

## FEATURES

- High selectivity and high sensitivity with one chip IC (Integrated Circuit).
- Fast tuning to key stations marked on the MW and LW dial scales (only for the models available in the United Kingdom and European countries).
- Fine tuning knob for easier tuning in SW reception.
- FM/SW sensitivity selector for stable reception.
- Two different power sources: batteries and house current.

## PRECAUTIONS

- Do not open the casing. Refer servicing to qualified personnel only.

- Operate the set only on 6V dc.

For ac operation, use the ac power adaptor recommended for this set. Do not use any other ac power adaptor.

- The nameplate indicating operating voltage, etc. is located on the rear exterior.

- Disconnect the ac power adaptor from the wall outlet when the set is not to be used for an extended period of time. The POWER switch on the set does not turn the ac power adaptor off.

- Do not leave the set in a location near heat sources such as radiators or airducts, or in a place subject to direct sunlight, excessive dust, moisture, rain, mechanical vibration, or shock.

- Should any liquid or solid object fall into the set, remove the batteries and disconnect the ac power adaptor, and have the set checked by qualified personnel before operating it any further.

- When the casing becomes soiled, clean it with a soft cloth dampened with a mild detergent solution. Never use abrasive cleansers or chemical solvents, as they may mar the casing.

If you have any question or problem concerning your set that is not covered in this manual, please consult your nearest Sony dealer.

## POWER SOURCES

### BATTERIES

#### Battery Installation

Insert four batteries, IEC designation R6 (size AA) with the correct polarity as indicated inside the battery compartment. See illustration [A] on page 3.

- The set cannot be operated on the internal batteries when the ac power adaptor is connected to the set.

- When the set is not to be used for a long period of time or is to be operated extensively on house current, remove the batteries to

avoid set damage caused by battery leakage and corrosion. To remove the batteries, see illustration [B] on page 3.

### Battery life

When listening to broadcasts from the speaker for four hours a day at a normal volume, you can expect Sony SUM-3(NS) New Super batteries to last for approximately 35 hours.

- The life of other type batteries or batteries of other manufacturers may be different.

- When the sound becomes weak or distorted, replace all the batteries with new ones.

### HOUSE CURRENT

Connect the appropriate ac power adaptor to the radio DC IN 6V jack, and then to a wall outlet. (See illustration [C] on page 3.)

Where used	AC power adaptor	Input voltage of adaptor
The United Kingdom	supplied	240 V ac, 50 Hz
Canada	supplied	120 V ac, 60 Hz
European countries (except Switzerland, Holland and West Germany)	supplied	220 V ac, 50 Hz
Switzerland Holland West Germany	AC-122 (optional)	110, 127, 220 or 240 V ac adjustable, 50/60 Hz

When the ac power adaptor is connected to the radio DC IN 6V jack, the internal batteries (if present) are automatically disconnected.

**Note:** Use only an ac power adaptor manufactured by Sony. Polarity of the plugs of other manufacturers may be different.



Polarity of the plug of Sony ac power adaptor

## HOW TO USE

To tune in a station, perform steps 1 to 7, referring to illustration **D** on page 4.

- 1 POWER switch/VOL (volume) control and indicator:** Turn the control clockwise to power on. Turn up for more volume. After using, be sure to turn towards POWER OFF until a click is heard.
- 2 BAND selector and indicator:** Choose the desired band, FM, MW, LW or SW.
- 3 Tuning knob:** Turn to select the frequency of the desired station, as marked on the dial scales.
- 4 SW FINE tuning knob:** Used for precise tuning in SW reception. First set the SW FINE tuning knob so that the mark on the knob is aligned with the mark of the set. And after tuning in a station, adjust the SW FINE tuning knob to tune in the station precisely. It doesn't matter how many times this knob has been turned.
- 5 TONE control switch:** Set to the upper position (H) for more treble and the lower position (L) for less treble.
- 6 FM/SW SENS (sensitivity) selector:** Normally set the selector to DX. If a very strong station signal causes noise or if multipath\* signals are heard, set it to LOCAL.
- 7 Telescopic antenna:** Adjust the antenna as required.  
**FM:** Pull out the telescopic antenna and adjust its length, direction, and angle for the best reception. See illustration **E-1** on page 5.  
**MW/LW:** When the BAND selector is set to MW or LW, the telescopic antenna is disconnected and the built-in ferrite bar antenna is used instead. Since this antenna is directional, rotate the set horizontally for optimum reception, if necessary. See illustration **E-2** on page 5.

**SW:** Pull out the telescopic antenna to its full length and stand it vertically. See illustration **E-3** on page 5.

**④ Dial scales:** The frequencies available within each band are marked on the corresponding dial scale.

### The U.K. model and European model

The key stations are marked on the MW and LW dial scales.

**⑤ TUNE (tuning) Indicator (LED):** Lights when a signal is received.

**⑥ DC IN 6V (external power input) jack:** For operation on house current, connect the appropriate ac power adaptor. See page 9.

**⑦ ⑧ (earphone) Jack:** For listening with an earphone. When an earphone is plugged in, the built-in speaker is automatically disconnected.

### ⑨ Battery compartment

**⑩ Stand:** Pull out when you want the radio free-standing and push in when not in use.

**⑪ Carrying handle:** Pull out when carrying the radio and hanging it on the wall, and push in when not in use.

\* Multipath, which often occurs in a street with big buildings or in a mountainous area, is a signal reflection from structures or hills that reach the receiver considerably later than a direct signal. A multipath condition brings about high-frequency noise, distortion, and a poor stereo effect.

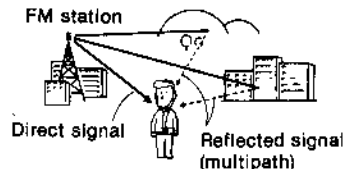

## SPECIFICATIONS

Frequency range	FM: 87.6–108 MHz (for the United Kingdom and Canada) 87.6–107 MHz (for European countries) MW: 530–1,605 kHz (566–187 m) LW: 150–255 kHz (2,000–1,176 m) SW: 5.95–18 MHz (50.4–16.7 m)
Antennas	FM/SW: Telescopic antenna MW/LW: Built-in ferrite bar antenna
Speaker	Approx. 9.2 cm (3 $\frac{5}{8}$ inches) dia.
Power output	500 mW (at 10% harmonic distortion)
Output	Earphone jack (minijack)
Power requirements	6V dc, four batteries, IEC designation R6 (size AA) The U.K. model: 240 V ac, 50 Hz with the supplied ac power adaptor The Canadian model: 120 V ac, 60 Hz with the supplied ac power adaptor The model for Switzerland, Holland and West Germany: 220 V ac (110, 127 or 240 V ac adjustable), 50/60 Hz with the optional AC-122 ac power adaptor The model for other European countries: 220 V ac, 50 Hz with the supplied ac power adaptor
Battery life	Approx. 35 hours with Sony SUM-3(NS) New Super batteries
Dimensions	Approx. 230 × 106 × 34 mm (w/h/d) (9 $\frac{1}{8}$ × 4 $\frac{1}{4}$ × 1 $\frac{1}{8}$ inches), incl. projecting parts and controls with the carrying handle pushed in
Weight	Approx. 580 g (1 lb 5oz), incl. batteries

While the information given is true at the time of printing, small production changes in the course of our company's policy of improve-

ment through research, and design might not necessarily be indicated in the specifications. We would ask you to check with your appointed Sony dealer if clarification on any point is required.

## TROUBLESHOOTING GUIDE

Should any problem occur with the set, make the following simple tests to determine whether or not servicing is required.

If the problem persists after you have made these tests, consult the nearest Sony dealer for further information.

### Sound does not come on at all.

- The VOL (volume) control is turned down.
- An earphone is plugged in.
- Incorrect polarity of batteries.
- The batteries are exhausted.
- The ac power adaptor is not firmly connected.
- Battery operation is attempted while the ac power adaptor is connected to the radio but not to a wall outlet.

### Very weak or interrupted sound, or unsatisfactory reception.

- Weak batteries.
- Improper tuning.
- Improper adjustment of the antenna.
- Weak signal. ⇒ In a building or a vehicle, place the radio near a window.